

PENTAGON

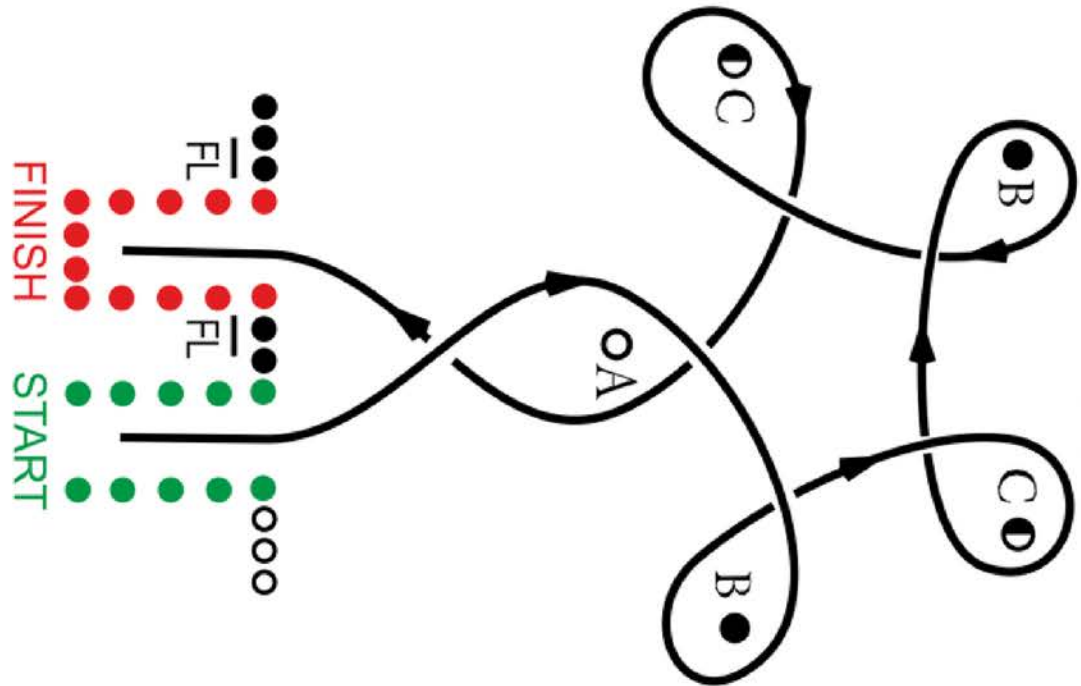

DOUBLE KIDNEY

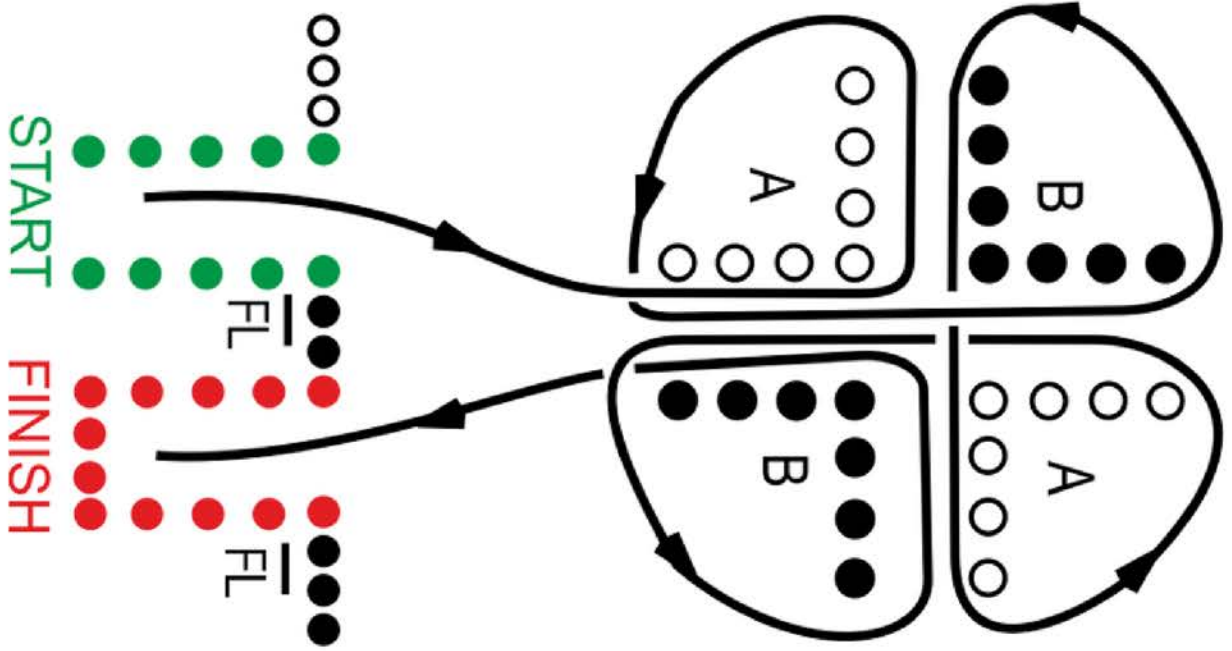

DOLLAR

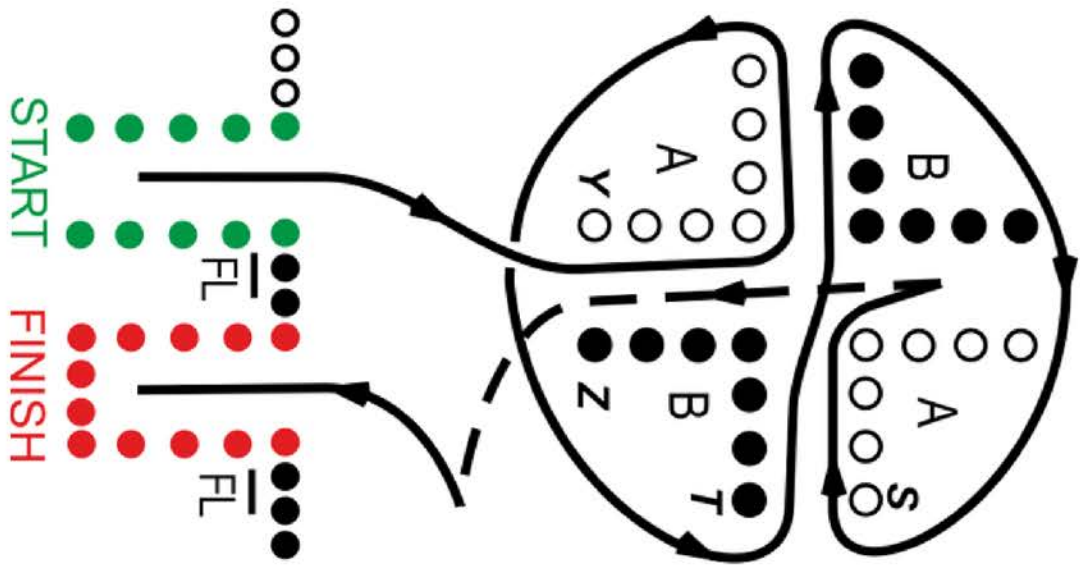

Reverse

MULTIPLE LOOP

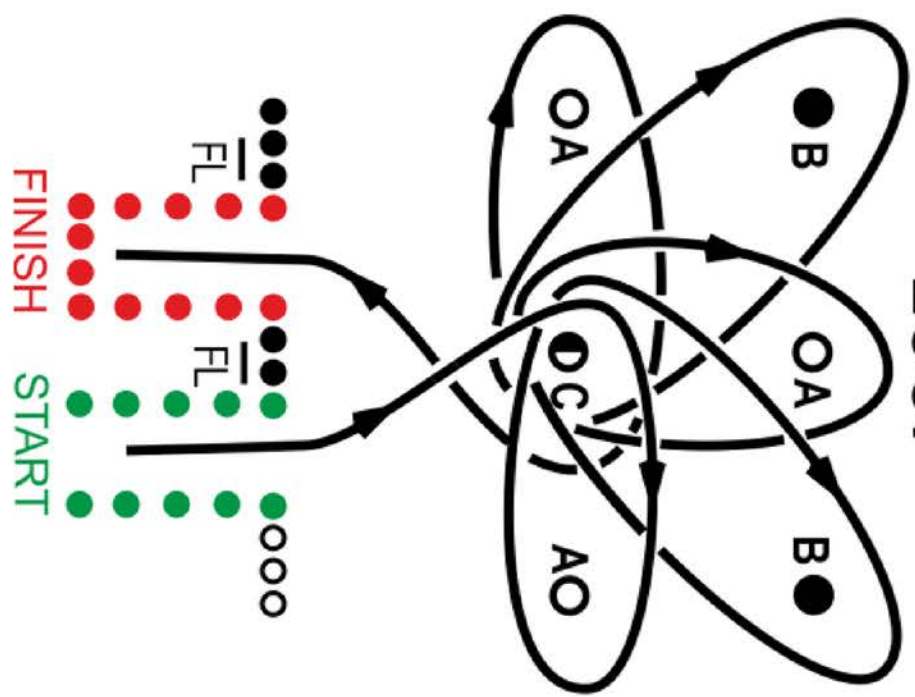

BUTTERFLY

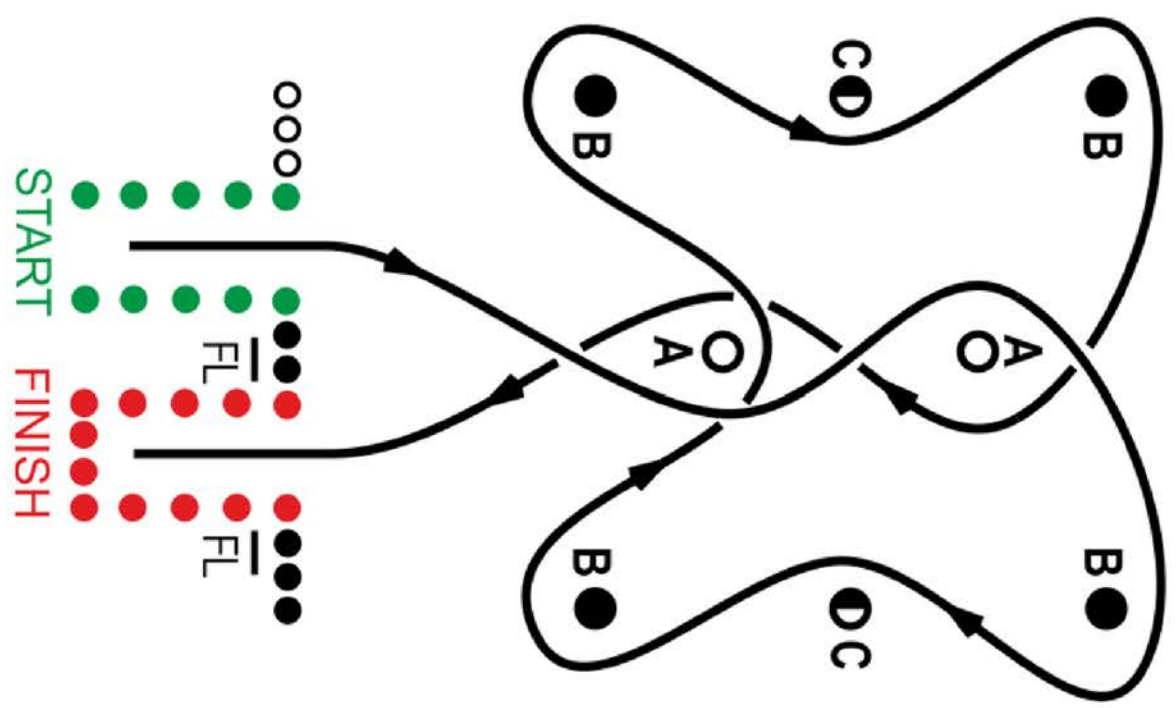

CORRIDOR

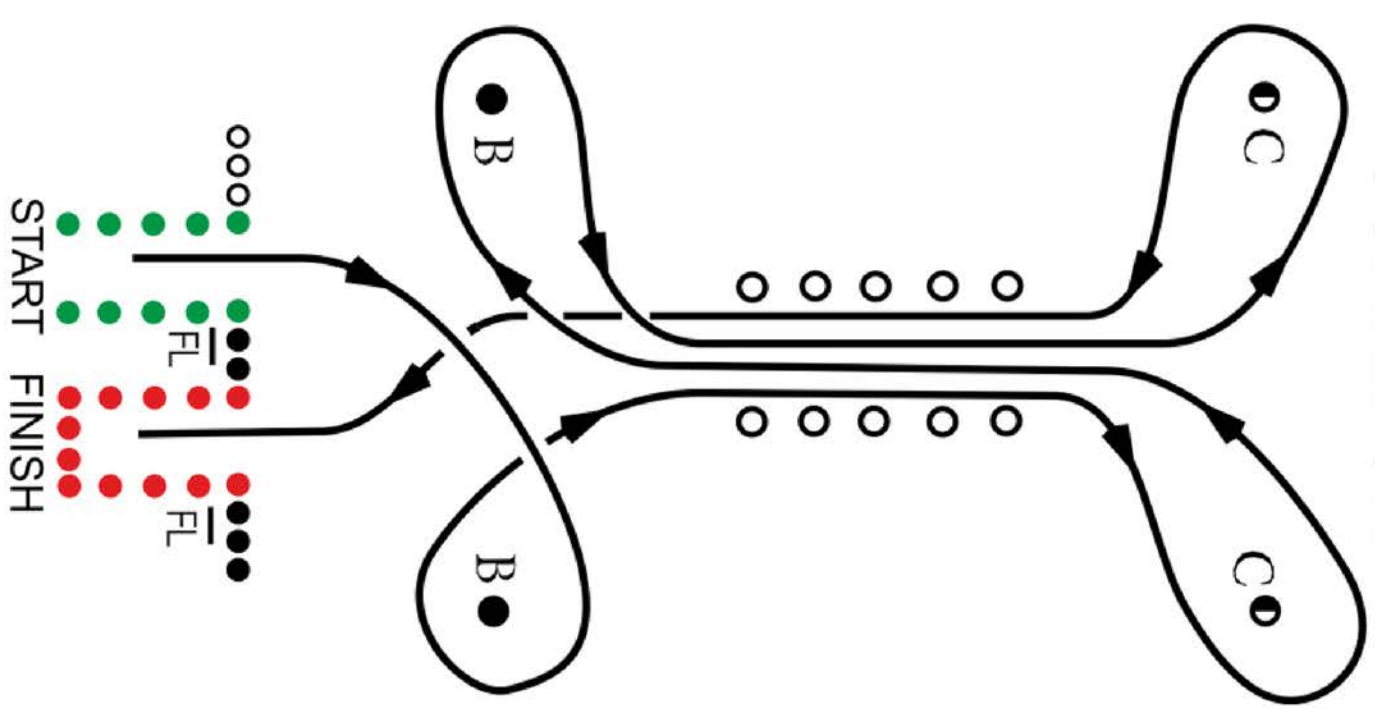

MOTHBALLS

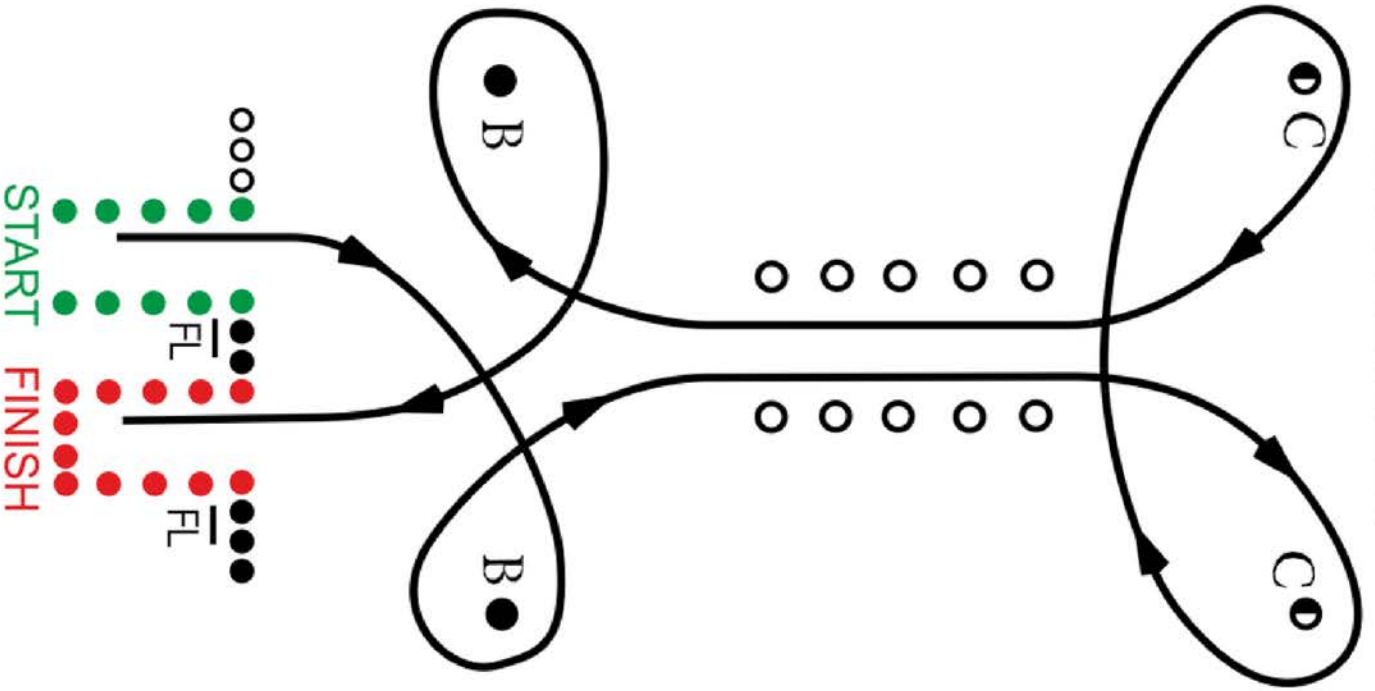

HOPKIRK

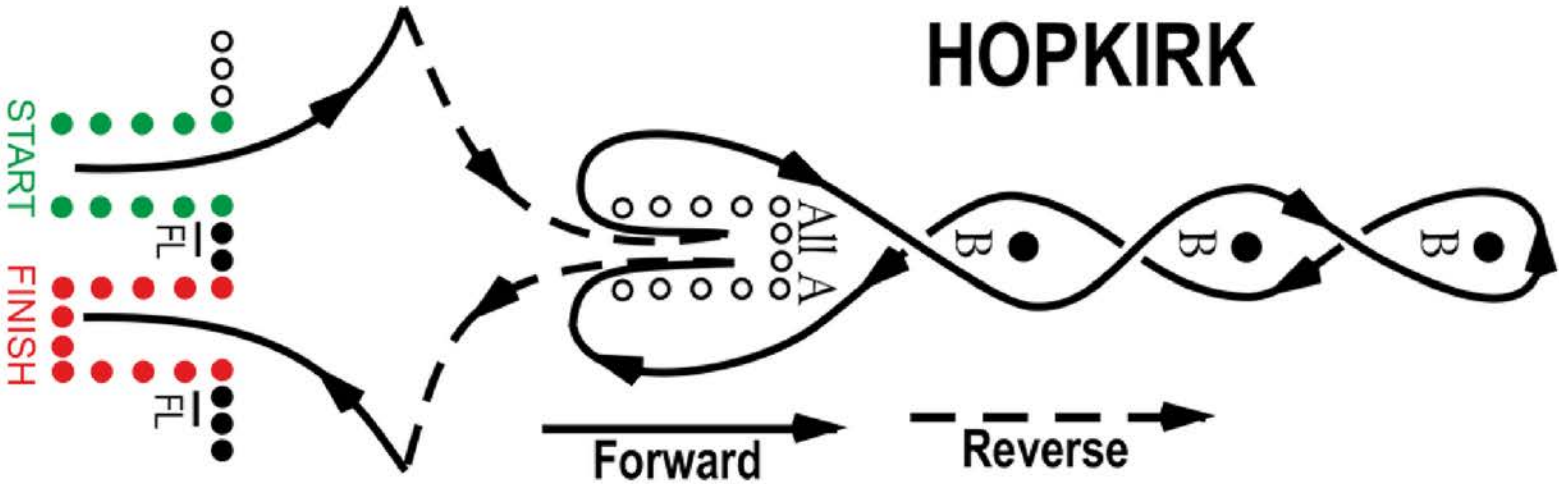

Turns, from forward to reverse and from reverse to forward, may be in either direction.
Field garage (O) shall be colour A.

PADDY

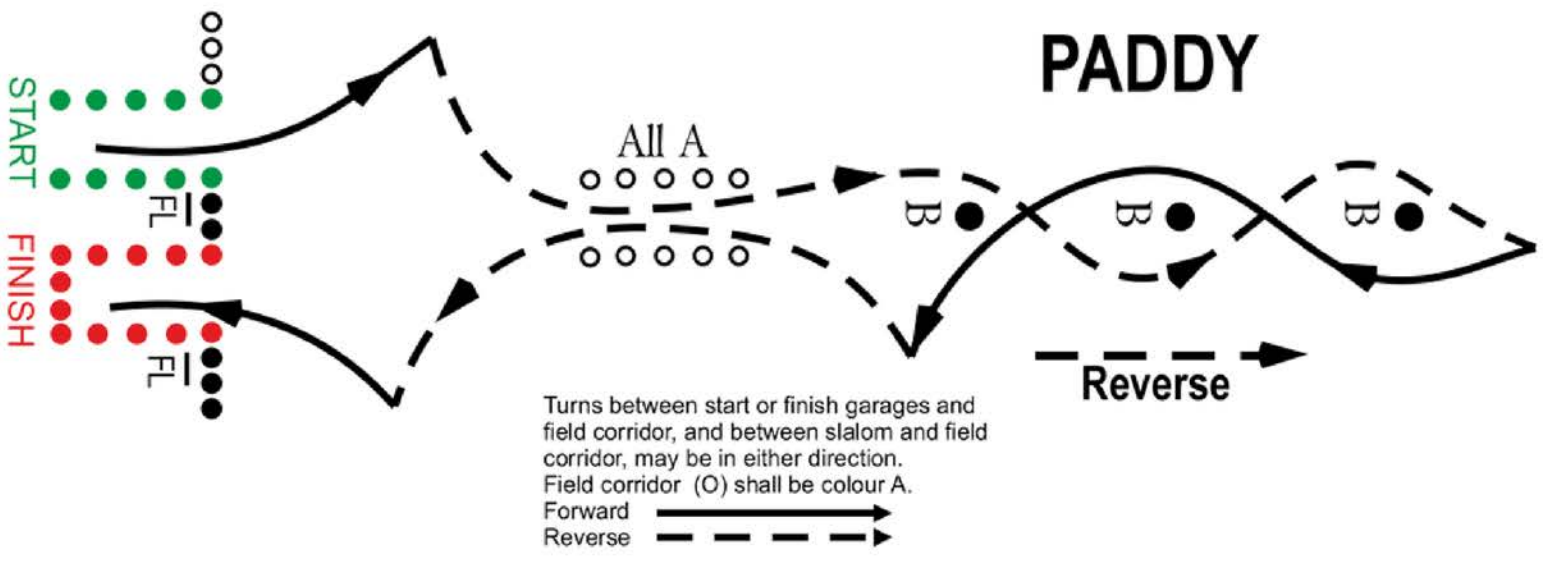

Turns between start or finish garages and field corridor, and between slalom and field corridor, may be in either direction.
Field corridor (O) shall be colour A.
Forward
Reverse